

# DM BATH

## INSTALLATION GUIDE MODELS DMV2402 / DMV3002 / DMV3602

Getting Started	01
Required Tools & Materials	01
Floating Vanity Installation	02
Drawer & Door Adjustment	03
Soft-Close Drawer Removal/Installation	03
Sink & Countertop Installation	04
Care & Maintenance	06
Limited Warranty	06
Technical Support	07

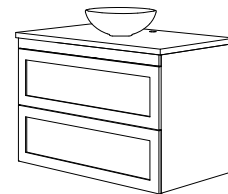
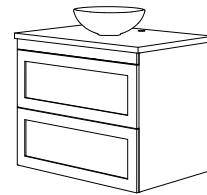
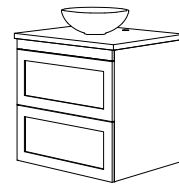

---

# Getting Started

**PLEASE READ CAREFULLY - IT IS RECOMMENDED THAT A QUALIFIED, LICENSED TRADES PROFESSIONAL INSTALL YOUR UNIT.**

All products must be inspected prior to installation. If damages are found due to transit or manufacturing defects then **DO NOT PROCEED WITH INSTALLATION** and advise supplier immediately. Manufacturer will not be liable for any installation, removal or re-installation costs. The warranty will be null and void if damage occurred during or after installation.

When installing the vanity cabinets – the drawers and doors may need to be adjusted, due to movement during shipping. Please view the instructions below on drawer and hinge adjustment.

Dezign Market accepts no liability for any damage to products or for any personal injury during installation.

## **Caution**

Any wall to which product is fixed must properly support the weight of the vanity, sink and countertop. Secure to stud framing or bracing (spanning the full length of the vanity) behind the finished wall. To ensure proper support and alignment, the finished wall must be straight, the floor must be flat and perpendicular to the finished wall.

When moving the vanity, do not slide or side-load the legs, doing so **WILL RISK DAMAGE TO THE VANITY.**

---

## Required Tools & Materials

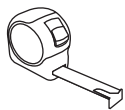

Tape Measure



Pencil

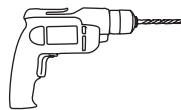

Electric Drill



Ø12mm



Phillips Screwdriver



Screws



Level

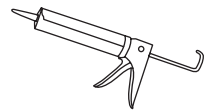

100% Silicone Sealant

# Vanity Cabinet Installation

**01.** Determine the vanity placement and mark the area on the wall where it will be installed. Check that the wall is straight, not bowed or twisted. Ensure vanity is square against the wall before securing. Drawer alignment could be affected otherwise.

**02.** All soft-close drawers must be removed before installation. Proceed to page 3 for instructions.

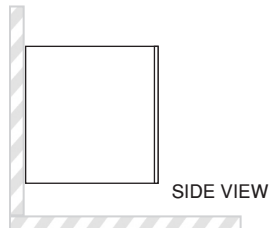

**03.** Vanity will have wall brackets pre-installed. Remove screws from brackets and vanity. Take brackets to mark proper measurement of vanity width and to wall studs. If the studs do not line up to the mounting location for your vanity, wood bracing can be installed between the studs using standard 2 x 4's behind the finished wall. This should be performed by a qualified licensed trade professional.

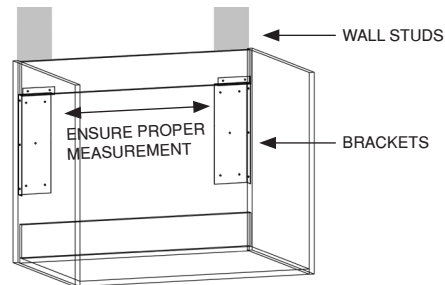

**04.** Use long screws supplied to drill screws into marked locations.

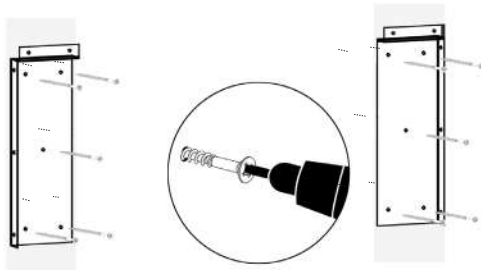

**05.** Lift cabinet over top of brackets and re-install screws previously taken out to tighten vanity into place.

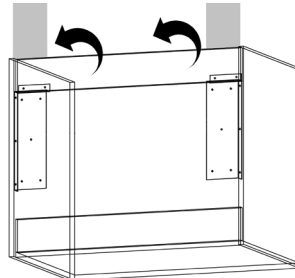

**06.** Attach the vanity to the wall by screwing through the vanity gable into the wall studs.

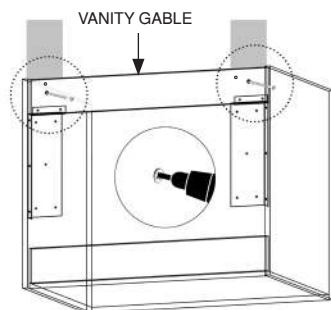

**07.** Re-install drawers and adjust if necessary. Refer to page 3 for instructions.

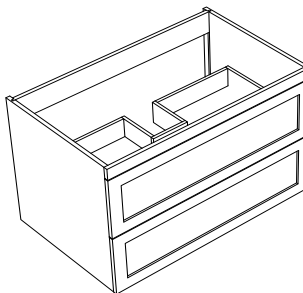

**08.** Follow instructions for SINK & COUNTERTOP INSTALLATION if using a DM BATH Countertop and Sink. If using a custom top and sink, follow Manufacturer installation.

For DM BATH VESSEL SINK & COUNTERTOP INSTALLATION, proceed to page 4.

For DM BATH UNDERMOUNT SINK & COUNTERTOP INSTALLATION, read COUNTERTOP INSTALLATION PRECAUTION on page 4 and proceed to page 5 for installation.

**09.** Choose the positioning of hardware of your choice (not included) on the vanity cabinet. Mark the screw hole location. Drill the cabinet with appropriate size bit to accommodate the screw diameter. Install your chosen hardware. Do not overtighten.

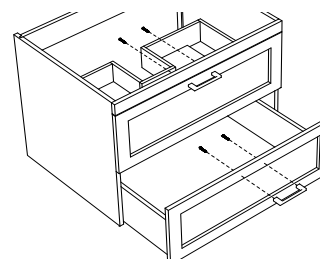

---

# Drawer & Door Adjustments

To make adjustments to doors or drawers please refer to the diagram below.

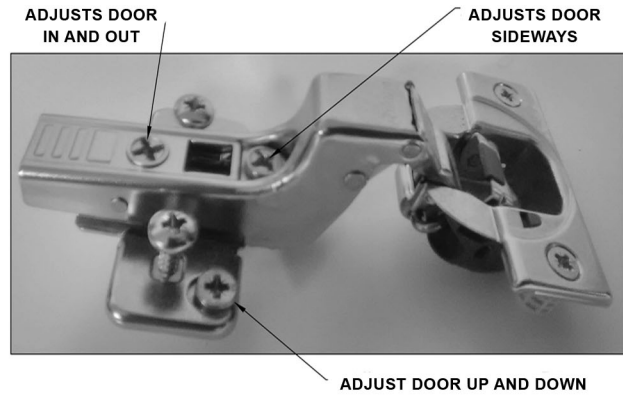
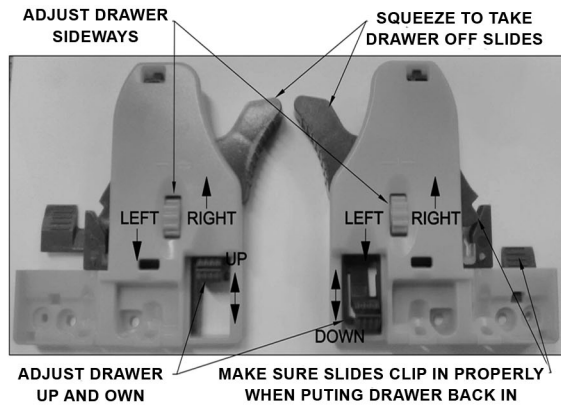

---

# Soft-Close Drawer Removal & Installation

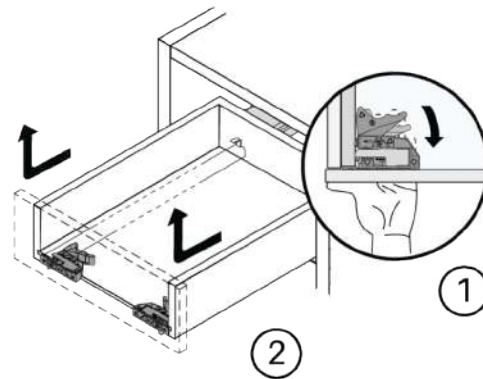
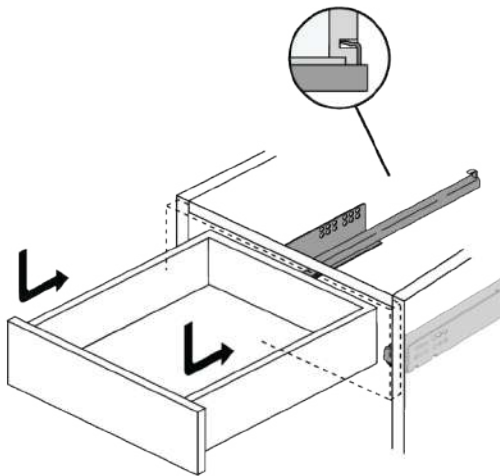

# Countertop Installation Precaution



**CAUTION - IMPORTANT HANDLING INSTRUCTION.  
NEVER LIFT OR CARRY THE COUNTERTOP FLAT.**

**BEFORE INSTALLATION** Examine and inspect the stone carefully ensuring no defects. If defects are found, DO NOT PROCEED WITH INSTALLATION and inform your dealer immediately.

**LIFTING COUNTERTOP** - Professional 2-Person crew required who are capable of handling the weight of heavy stone tops. You may require 3-Person crew for double vanity tops. Lift the countertop from the front edge, bringing to a vertical position, while keeping the back edge in the box. IT IS IMPORTANT to support the countertop in a vertical position. Support the countertop from the bottom and centre weight. Double vanity countertops may crack easily without proper center support.

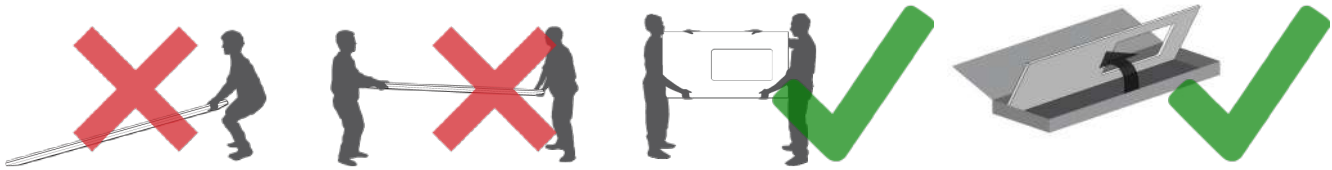

## Vessel Sink & Countertop Installation

**01.** Read lifting pre-caution above. Remove the countertop from the box while maintaining its vertical position. Lift countertop over cabinet base carefully while still maintaining its vertical position. Gently place the edge of top at the back of the cabinet making sure aligned. Lower top to cabinet make sure both ends come down at the same rate.

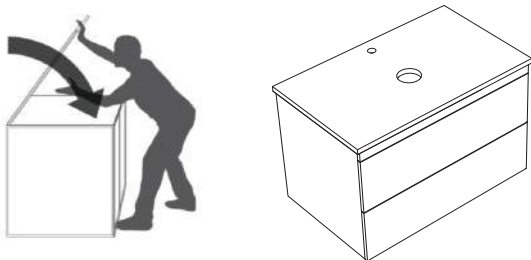

**02.** If you have a DM Bath Backsplash and/or Side Splash, install next. Apply 100% Silicone Sealant on the back of the backsplash/sidesplash. Vertically align back/side splash making sure it is aligned to countertop. Press into place.

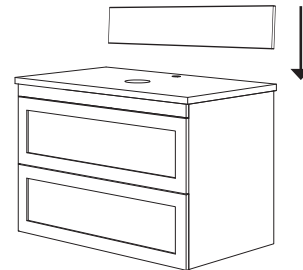

**03.** Clean the surface of vessel cut-out on countertop. Generously apply 100% Silicone Sealant around the bottom of the vessel sink. Position sink under the opening. Hold the sink in place. Immediately wipe away any excess sealant.

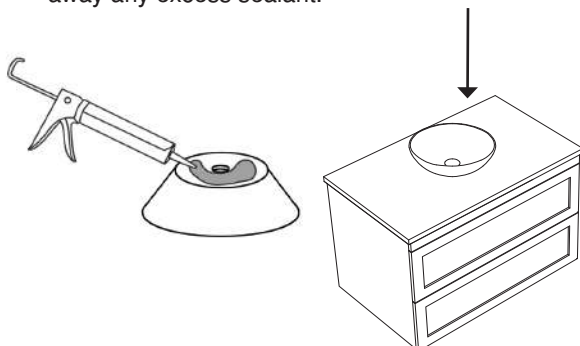

**04.** Complete the faucet and drain installation according to Manufacturer's Installation guide.

# Undermount Sink & Countertop Installation

- 01.** Read lifting pre-caution above. Remove the countertop from the box while maintaining its vertical position. Carefully turn the counter top over, resting it on a soft, stable surface to prevent damage.

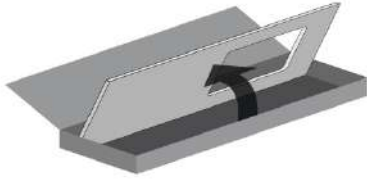

- 02.** Position the undermount sink over the sink cutout on the counter top. Make sure the sink is centered with the faucet hole and is evenly spaced. Draw an outline of the sink with pencil on the countertop.

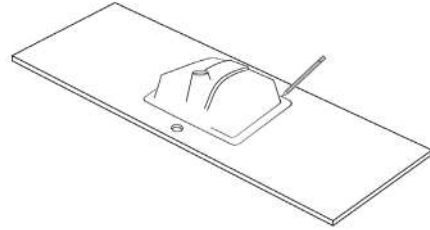

- 03.** Generously apply 100% silicone sealant around the rim of the undermount sink.

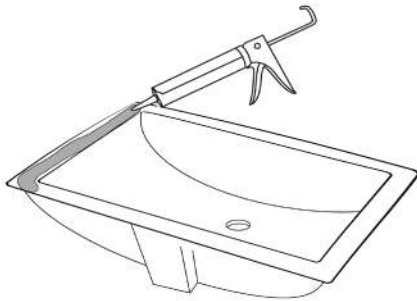

- 04.** Position and hold the sink at the opening ensuring to follow your outline. Immediately wipe away any excess sealant. Let dry for 24 hours.

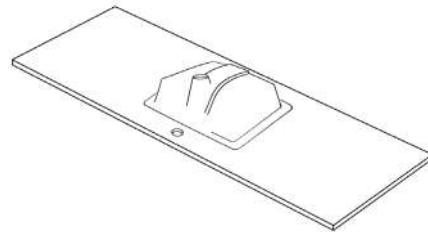

- 05.** Carefully turn the countertop and sink over. Place the top on the vanity while maintaining a vertical position. Gently place the edge of top at the back of the cabinet making sure aligned. Lower top to cabinet make sure both ends come down at the same rate.

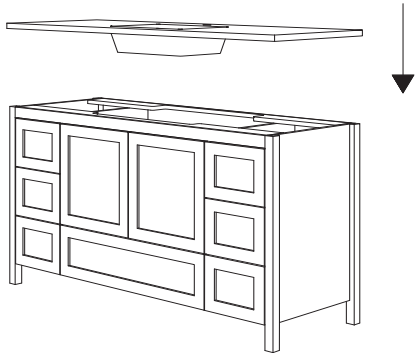

- 06.** If you have a DM Bath back/side splash, install next. Apply 100% silicone sealant on the backside. Vertically align back/side splash making sure it is aligned to countertop. Press into place. Immediately wipe away excess sealant. Let dry for 24 hours.

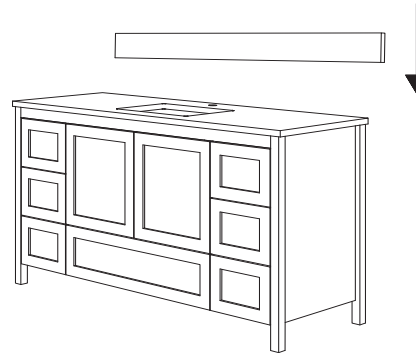

- 07.** Complete the faucet and drain installation according to Manufacturer's Installation guide.

---

## Care & Maintenance

To maintain the finish of your cabinet and countertop, use a clean soft cloth, lukewarm water and non-abrasive detergent. To avoid deterioration it is important to keep surfaces dry of any moisture. Avoid exposure to chemicals, solvents, acids and abrasive agents. Avoid contact with household chemical substances, such as toothpaste, mouthwash, lipstick, perfumes etc. Should your surface be exposed to any of these damaging products by accident, clean immediately with soft cloth and lukewarm soapy water. Avoid use of highly aggressive cleaning agents, abrasive powder or cream. When using professional cleaning products, follow the manufacturer's instruction carefully and always test your cleaning solution on a small-unexposed area before applying to the entire surface.

### Cleaning Difficult Stains on Quartz Countertop

Avoid exposure to any strong chemicals and solvents on your quartz countertop. You should first try removing stain with:

- A regular eraser.
- Mild liquid soap and water solution.
- A natural stone/quartz over-the-counter cleaning solution by buffing with a soft cloth or Mr. Clean magic eraser sponge.

For the purpose of spot cleaning difficult stains a solvent like acetone can be acceptable. It should ONLY be used for short-term exposure at 50% dilution based on removing and rinsing applied area immediately after.

## Limited Warranty

### **DM Bath products (Bathroom vanities, mirrors, countertop, side/backsplash & sinks) carry a 2-year limited warranty free from defects in material and workmanship for residential installations only.**

This commences on the date of product shipment to the dealer or, if shipped direct, on the date of shipment to the customer. If such a defect appears during the terms of this warranty, manufacturer will, at its own discretion repair, replace the defective part(s) or the defective product, with the same or existing product of similar value, free of charge, excluding installation and destination shipping costs.

- This warranty applies only to the original purchaser for the products that are subject to residential installation only. This warranty is void if the product has been moved from its initial place of installation or has been used for commercial, industrial or other non-residential use.
- Warranted item must have been purchased only from an authorized Dezign Market dealer, carrying DM BATH products. A copy of the original purchase receipt is required for validation.
- Customer assumes responsibility for all merchandise received in original condition upon delivery.
- All defects must be reported as soon as possible, prior to install, not exceeding three (3) business days from date of delivery. Failure to do so will result in denial of claim. No damage claims will be accepted after that.
- It is the customer's responsibility to investigate all end user complaints regarding Dezign Market products. To make a claim for a defective product, please have a digital photo taken of the defective product, please have a digital photo taken of the defect and send it via email to [info@dezignmarket.com](mailto:info@dezignmarket.com) with detailed description.
- This warranty excludes the coverage of any costs incurred in the removal, re-installation and shipment of the replacement product or the replacement parts, or any consequential damages.
- This warranty does not protect against malfunction or other failure caused by accidents, alterations, abuse, neglect or misuse including, but not limited to: improper handling or storage conditions; damage during installation; faulty maintenance, harsh detergents or abrasive cleaners; damage caused by fire, water, radical temperature fluctuations or inadequate air circulation at the place of installation; repairs or modifications of any kind, including painting, by persons not authorized by the manufacturer; or use for purposes other than intended or in locations subject to conditions not intended for the product(s).
- Normal wear and tear is not considered defect and not covered under warranty, including minor scratches or chipped counters.
- This warranty does not apply to local building or plumbing code compliance. It is the consumer's responsibility to determine local code compliance prior to purchase and installation.
- This warranty is in lieu of all other warranties, expressed or implied, and the only one recognized by the manufacturer.
- To prolong the lifetime of DM BATH product(s), the recommended manufacturer's installation and maintenance procedures must be strictly followed.
- Dezign Market shall make the final determination on any issue or uncertainty regarding the application of this warranty.

**If the above limits and conditions are not met, the warranty will be null and void.**

---



## **Technical Support**

Our customer support department is available Monday - Friday 10:00 a.m. - 5:00 p.m. EST.  
We can help with any questions you may have.

**1 888 398 8380**  
**support@dezinmarket.com**

**DEZIGNMARKET.COM**

---