

NOTES:

1. TO INSPECT ASSEMBLY, FOLLOW FIRST ARTICLE AND IN PROCESS INSPECTION SHEET.

BILL OF MATERIAL (CURRENT LEVEL)

ITEM	PT/ASSY	DESCRIPTION	TYPE	QTY.
1	3-638	W/M LAVATORY SPOUT W/ESC.	ASSEMBLY	1
2	3-645	CROSS HANDLE W/ESC.	ASSEMBLY	2

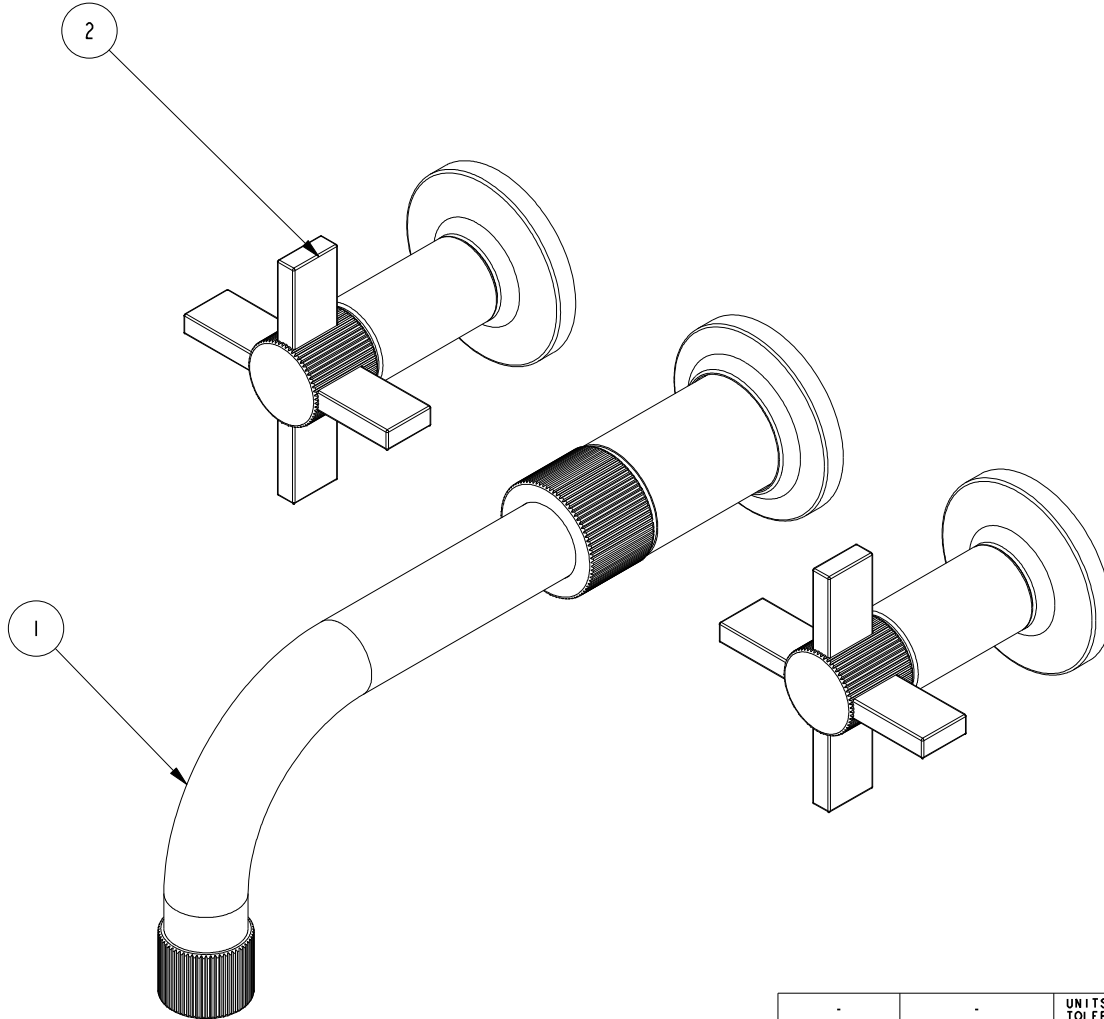

ZONE	REV	DESCRIPTION	DATE	APPROVED
-	A	EN-3961-2	05/28/20	J.M.
-	-	EN-3478	01/16/19	J.M.

COPYRIGHT 2005 BRASSTECH, INC. THESE DRAWINGS AND THE DESIGNS DEPICTED HEREIN ARE THE PROPRIETARY PROPERTY OF BRASSTECH. ANY USE OR REPRODUCTION IS SUBJECT TO THE EXPRESS APPROVAL OF BRASSTECH. UNAUTHORIZED USE IS STRICTLY PROHIBITED. ALL RIGHTS RESERVED.

TESTING	-	-	-
ASSEMBLY	-	-	-
PLATING	-	-	-
POLISHING	-	NEXT ASSY	USED ON
MACHINING	-	APPLICATION	
TOOLING FIXTURE #	REMOVE ALL BURRS AND SHARP EDGES		

UNITS ARE: INCHES [MM]		
TOLERANCES ARE:		
FRACTIONS	DECIMALS	ANGLES
±1/16"	.X ±.1 [2.5]	±1°
	.XX ±.06 [1.5]	
(X.XXX) DENOTES CRITICAL DIMS. ALL THREADS ARE CRITICAL		
DRAWN	JIMSON	01/16/19
CHECKED	J.M.	01/16/19
APPROVED	J.M.	01/16/19

BRASSTECH 2001 CARNEGIE AVE. SANTA ANA, CA 92705 (949) 417-5207
INCORPORATED

WALL MOUNT LAV FAUCET

DWG NO.	3-3241	REV	A
SCALE	.500	REF.	-
SHEET	1	OF	3

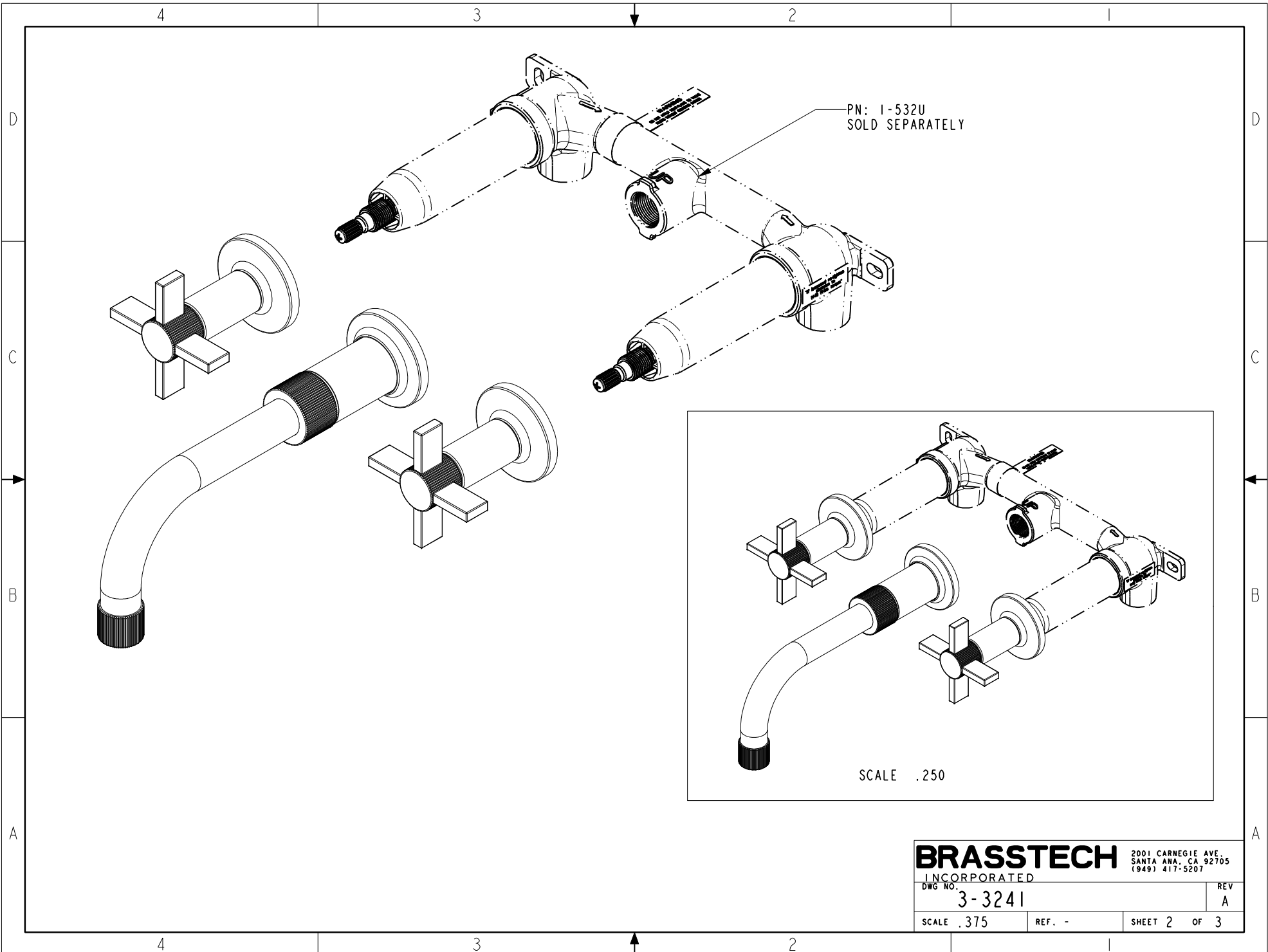

BRASSTECH 2001 CARNEGIE AVE.
INCORPORATED SANTA ANA, CA 92705
(949) 417-5207

DWG NO.	3-3241	REV	A
SCALE	.375	REF.	-
		SHEET	2 OF 3

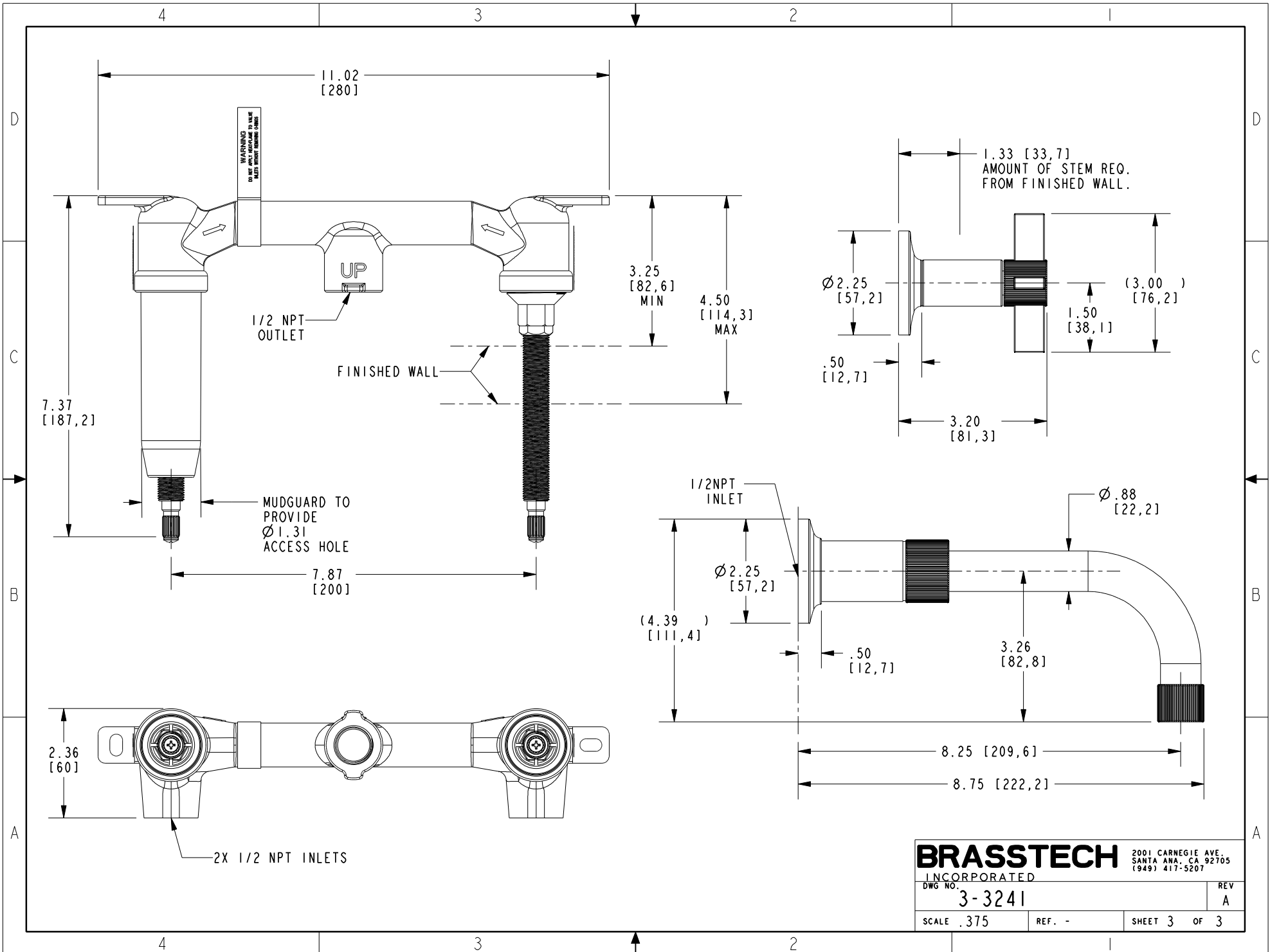

WARNING
DO NOT USE
LEFT WHIST TRAINING CHAINS

UP
1/2 NPT
OUTLET

FINISHED WALL

MUDGUARD TO
PROVIDE
Ø 1.31
ACCESS HOLE

1/2 NPT
INLET

1.33 [33,7]
AMOUNT OF STEM REQ.
FROM FINISHED WALL.

BRASSTECH
INCORPORATED
2001 CARNEGIE AVE.
SANTA ANA, CA 92705
(949) 417-5207

DWG NO. 3-3241	REV A
SCALE .375	REF. -
SHEET 3	OF 3